

# Counterbalance and Pilot-to-Open Check Cartridges

## Design Concepts, Features, and Applications

Sun offers a wide variety of load holding and motion control cartridges to satisfy the most demanding applications. Some things to consider when applying cartridge valves:

- Cartridges can be mounted in, at, or near cylinders and motors to protect against hose failure and to improve system “stiffness.”
- Some systems have enormous momentum due to large masses in motion. This kinetic energy must be handled very carefully.
- Some mechanical system components also store energy with high compliance (such as a spring) due to flexible members, rubber tired platforms, and long hose lines acting as accumulators. This stored energy must be handled very carefully.
- Spring/mass networks are natural oscillators with a wide variation in natural frequencies, and can result in unplanned system oscillations.

The following information is intended to provide some advice -- some rules of thumb -- to assist in selecting an appropriate valve for a particular application. It is possible that many different valves will work satisfactorily in a given application. It is also possible that no cartridge listed on our web site will perform acceptably. Sun has anticipated and prepared for system problems in the following ways:

- All Sun’s three-port and four-port load holding and motion control cartridges of a given frame size are physically and functionally interchangeable (same cavities, same flow path). This makes it easy to empirically optimize system performance by trial and error.
- In addition to the valves on the web site, Sun regularly manufactures and may carry in stock additional interchangeable cartridges with useful characteristics.



CBCA

CWCA

- Emergency manual-release screws are available (standard or optional) on most cartridges.
- Malfunctioning cartridges can be removed for easy replacement, inspection, and cleaning without altering adjustment settings. Great care must be taken to insure that machines are mechanically held in position and the cartridges are not under pressure at the time cartridges are removed. Stored energy can be extremely dangerous.
- Sun valves are designed for long service, but wear and tear on critical seating faces can and does take place. Shock tends to coin seats. Oil-borne contamination and water tend to erode seats. Gentle use tends to burnish and improve seats. Heavy contamination (sludge) can cause working elements to seize and lock valves open or closed.

NOTE: The servicing of hydraulically actuated machinery should always be carried out by trained personnel. Good service manuals are important. Applicable instruction and warning plates mounted on machines should always be followed.

Sun offers two basic types of load holding cartridges with several variations of each type.

## Pilot-to-Open Check Cartridges

### Three-Port Pilot-to-Open Check Cartridges — **CK\*\***

Three-port pilot-to-open check valve cartridges are **non-modulating, on/off devices** that allow free flow from port 2 (inlet) to port 1 (load) and block reverse flow until a pilot pressure **directly proportional** to the load pressure is applied at port 3 (pilot) to allow the pilot piston to push the check poppet off its seat and allow flow from port 1 to port 2. Pilot-to-open check valves are not suitable devices for modulating flow or controlling the speed of a hydraulic actuator.

#### Pilot-to-open check valve characteristics:

- Operating pressures up to 5000 psi (350 bar).
- Rated flow capacity up to 120 gpm (460 L/min.).
- Pilot ratio 3:1 (Pilot ratio 5:1 available standard in Series 1 frame size; other sizes may be available).
- Optional emergency manual release screw available (in case pilot pressure is not available to open).
- Optional check valve springs available: 15 psi (1 bar) is the minimum recommended to avoid shock damage. 4 psi (0,3 bar) is used to minimize cavitation.
- Intentional minor leakage past the pilot piston is standard (port 2 (inlet) to port 3 (pilot)) to purge trapped air in the pilot line. Optional sealed pilot pistons are offered for circuits demanding no cross-port leakage.
- Back pressure at port 2 directly opposes pilot pressure at port 3.

### Four-Port Vented Pilot-to-Open Check Valves — **CV\*V**

Four-port vented pilot-to-open check valves pilot pressure requirements are insensitive to pressure in port 2. These valves retain the pilot at port 3, and add port 4 as a vent port. All have a pilot piston seal to prevent port 3 to port 4 leakage or vice versa. (A three-port atmospherically vented version (CK\*V) is available for retrofit into three-port cavities where back pressure is causing piloting problems.)

## Counterbalance Cartridge Valves

### Three-Port Counterbalance Valves — **CB\*\***

Three-port counterbalance cartridges (with pilot-to-open assist) are modulating devices that allow free flow from port 2 (inlet) to port 1 (load) and then block reverse flow until a pilot pressure inversely proportional to the load pressure is applied at port 3 (pilot). The modulation of a counterbalance valve is a function of both the load pressure and the pilot pressure, yielding an “inverse pilot ratio.” Light loads require more pilot pressure and heavy loads less pilot pressure to open the counterbalance valve, helping to improve stability and provide fine motion control.

Counterbalance valves control motion by guaranteeing the directional valve always sees a positive load pressure, even with overrunning loads. Sun counterbalance valves (with pilot-to-open assist) will shut off with very low (approaching zero) leakage. Absent nicks in the seating area, silting (even with “clean” oil) will normally produce a zero leak seal within minutes after closing. Deceleration control of moving loads can be provided with the proper selection of directional valves and/or circuitry. They also incorporate a relief function from port 1 (load) to port 2 (inlet) which provides protection from load and/or thermal over pressure. Three-port counterbalance valves with reverse flow check valves are suitable for counterbalancing **constant fixed loads** where the valve is set at 1.3 times the constant load induced pressure, with Port 3 not used.

#### Counterbalance cartridge valve characteristics:

- Low leakage on closing. Specification maximum leakage is 5 drops/minute (0,4 cc/minute) at 85% of setting on reseating.
- Low relief valve hysteresis over a wide flow range.
- Good tolerance to contamination.
- Operating pressures to 5000 psi (350 bar).
- Flow capacities to 120 gpm (460 L/min.).
- Adjustment screw can be used to lower the setting, providing an emergency manual release when pilot pressure is not available.
- Optional check valve springs available. 25 psi (1,7 bar) is standard and recommended to avoid normal shock damage. 4 psi (0,3 bar) is available to minimize cavitation.
- Intentional minor leakage past the pilot piston is standard on many valves to purge air from the pilot line and improve stability. Sealed pilot pistons are standard on some models.

## Counterbalance Cartridge Valves (continued)

### Four-Port Vented Counterbalance Valves with Pilot-to-Open Assist — CW\*\*

Back pressure on standard non-vented counterbalance valves causes the effective setting to be increased by a factor of  $1 + \text{pilot ratio} \times \text{back pressure}$ . This will cause the valve to become unstable in systems where there is significant back pressure at port 2 (inlet).

Sun four-port counterbalance valves add a drain port (port 4) to the cartridge which makes the valve insensitive to back pressure at port 2. This makes four-port counterbalance valves useful in regenerative circuits, with meter-out directional valves, and proportional and servo valves.

They are available in a variety of pilot ratios and have the same general specifications as three-port valves. One model has a maximum setting of 6000 psi (420 bar). A three-port, atmospherically vented version (CA\*\*) is available for retrofit into three-port cavities where unexpected back pressure creates a problem.

Example of a Typical Motor Circuit\*

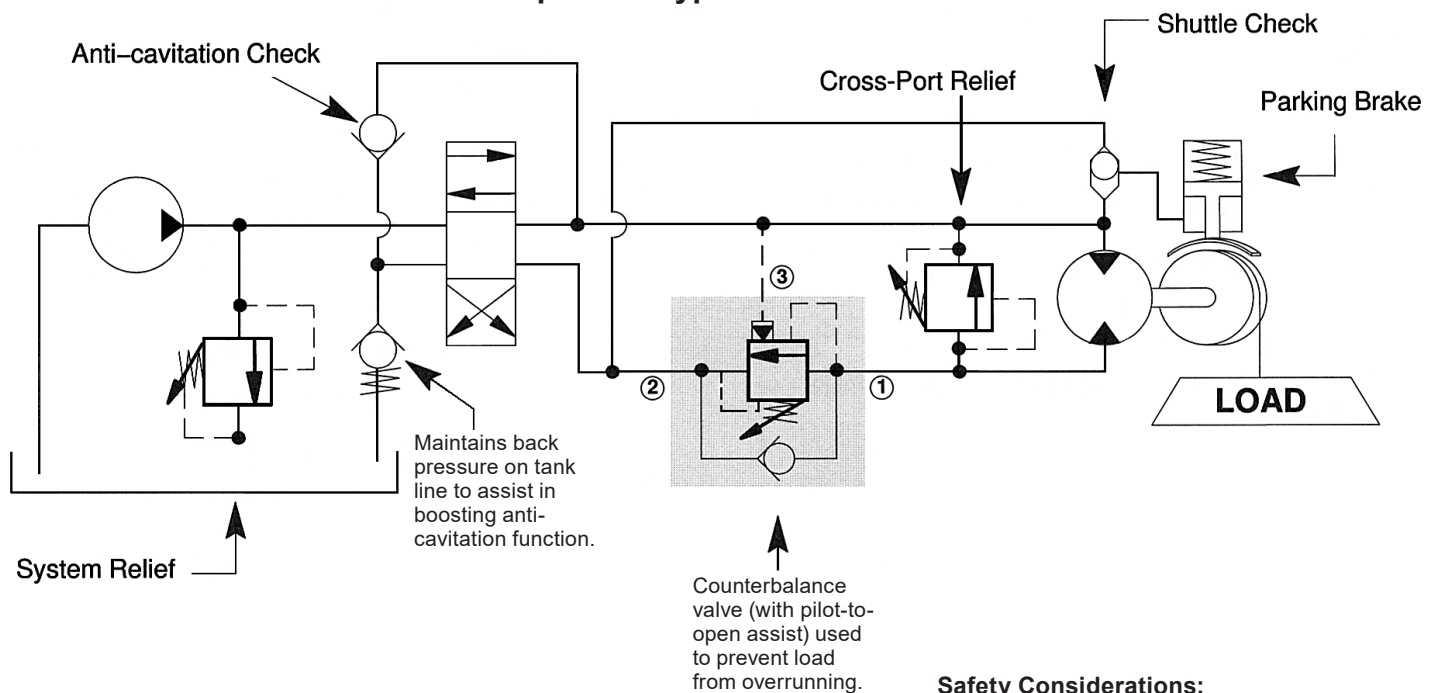

**Safety Considerations:**

- 1) Always employ a parking brake to hold motor loads.
- 2) Always use tamper-resistant adjustment protection on counterbalance valves.
- 3) Consider using separate cross-port relief protection and supercharged anti-cavitation protection, especially with cold oil, long lines, and elevated hydraulic motors.

\*This drawing is not a real circuit and is intended for description only.

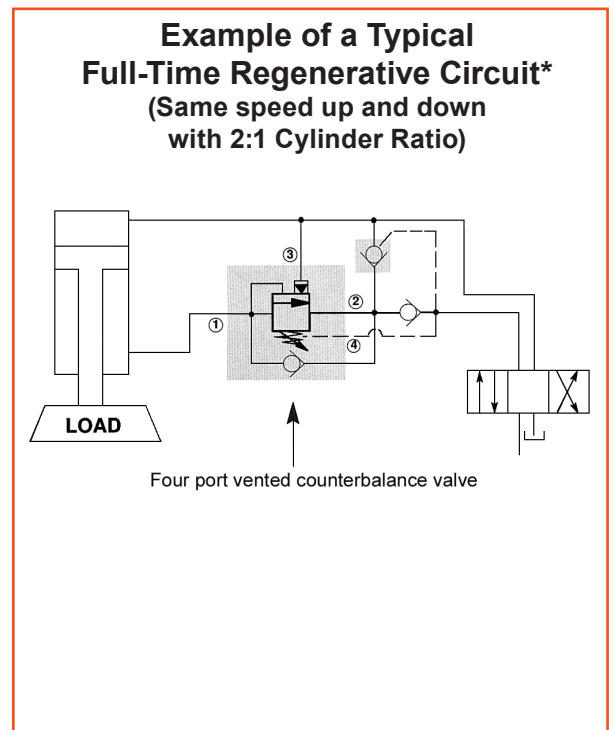
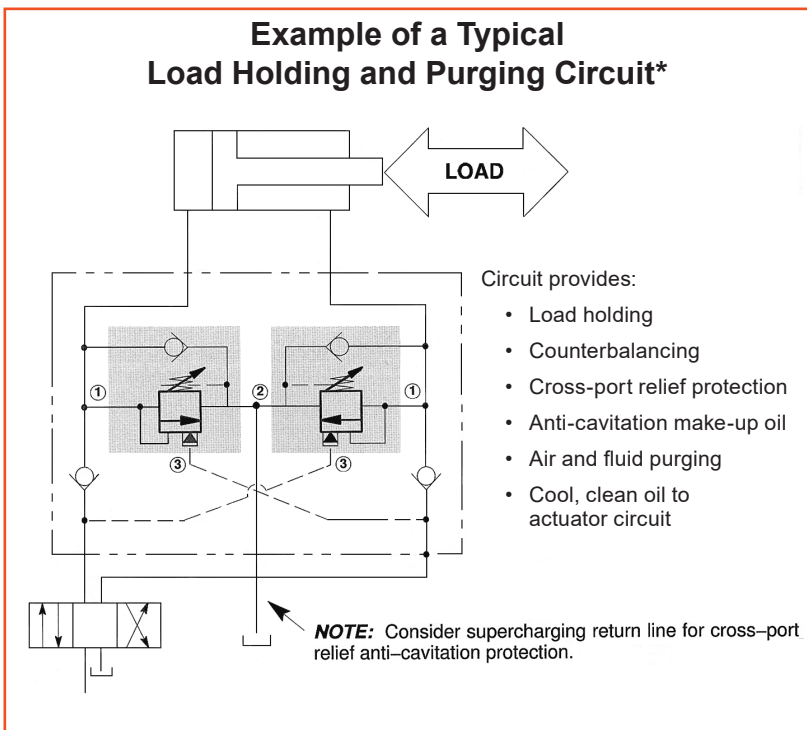
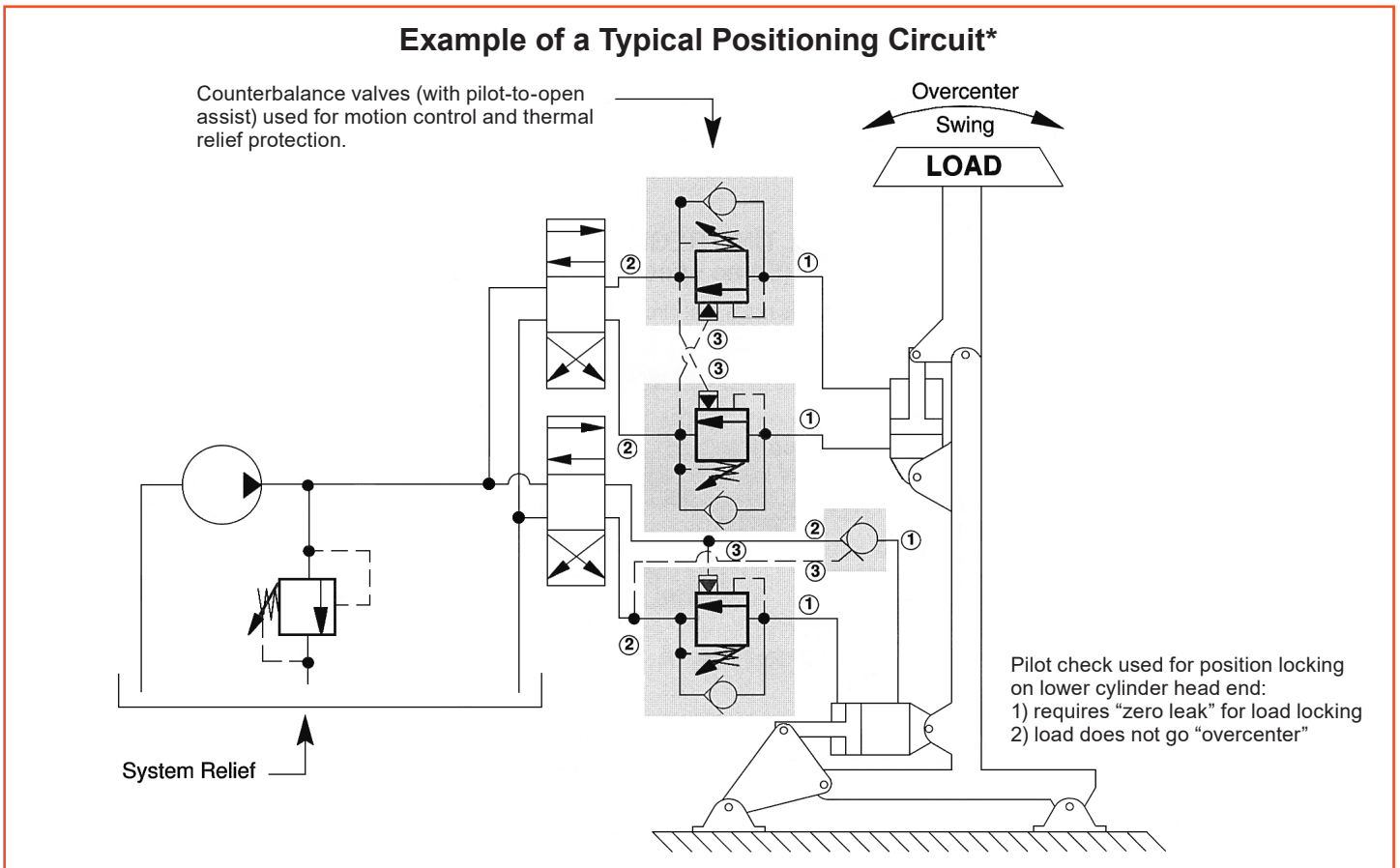

\*These drawings are not real circuits and are intended for description only.

## Pilot-to-Open Check Valves Application Notes

### Pressure Required to Release Load

**NOTE:** The following equations are idealized. Back pressure at port 2 is excluded from these equations, and check cracking pressure is ignored.

Where:

L = Load-Induced Pressure

P = Pilot Pressure Required to Open Valve

P<sub>R</sub> = Pilot Ratio (e.g. 3:1 = 3)

C<sub>R</sub> = Cylinder Area Ratio =  $\left( \frac{\text{Bore Dia}^2}{\text{Bore Dia}^2 - \text{Rod Dia}^2} \right)$

1) Pilot check on the blind end of the cylinder with a load retracting the cylinder rod.

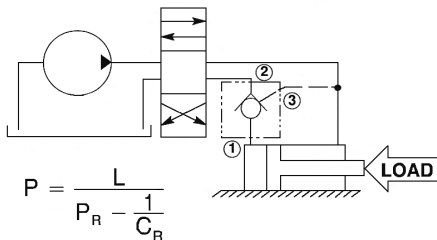

2) Pilot check on the rod end of the cylinder with a load extending the cylinder rod.

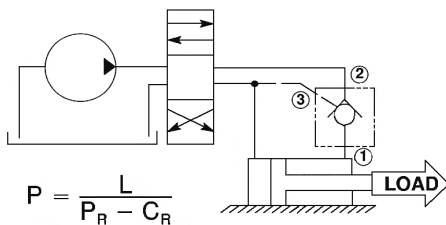

**NOTE:** Cylinders with large area ratios (2:1) loaded to extend utilizing pilot-to-open check valves may self-lock. If the cylinder area ratio is close to the check valve pilot ratio, the denominator in the above equation tends toward zero, and drives pilot pressure to open the valve toward infinity. The resulting cylinder pressure intensification in the cylinder rod end rises faster than the check valve pilot ratio can overcome. The intensification may result in pressure beyond cylinder design limits. For these applications consider using a counterbalance valve with 10:1 pilot ratio.

3) Pilot check on an equal area actuator.

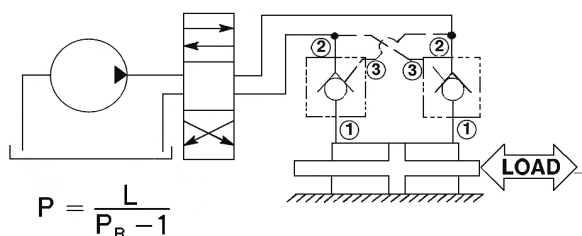

- It is preferable that the valve be mounted close to the actuator, providing maximum protection in the event of a hydraulic line failure. This can be achieved by incorporating them directly into the actuator. Sun also offers a range of gasket-mounted bodies that bolt directly onto the mounting face of a cylinder or motor.
- A pilot-operated check is a non-modulating device and is **not** suitable for smooth motion control or overrunning loads. (It is a load holding valve, not a load lowering valve. When trying to lower a load, severe machine “ratcheting” may result!)
- Pilot pressure for a pilot-operated check valve is **directly** proportional to load pressure.
- Back pressure at port 2 **directly opposes** the pilot pressure at port 3 and is additive to it. If port 2 is pressurized (for example in regenerative circuits) then a four-port vented pilot-to-open check valve should be considered.
- Four-port vented pilot-operated checks should be vented back to the circuit immediately down stream of the restriction causing the back pressure.
- In the vent-to-atmosphere (CK\*V) three-port version, the pilot spring chamber is vented externally to atmosphere through a vent hole in the cartridge. An o-ring is fitted over the hole to minimize the ingress of dirt and moisture into the spring chamber. *External leakage (“weepage”) equates to one drop for every 4000 cycles.* This cartridge fits into the standard three-port cavity and is useful if the check valve needs to be made insensitive to unanticipated system back pressure in existing systems. However, the four-port version is preferred for new system designs.
- Use care when utilizing cylinders with large area ratios and pilot-to-open checks on the rod to hold the load. Under some conditions, “load locking” may occur. See note and formulas under the heading “Pressure Required to Release Load” in the left column.
- Pilot-to-open check valves have very low leakage. New valves have one drop or less leakage per minute. Applications with high shock and/or contaminated oil can cause degradation of the seat resulting in increased leakage. If near zero leakage is required over time, some applications may require routine replacement of the pilot-to-open check valves.

## Counterbalance Cartridge Valves Application Notes

### Pressure Required to Lower Load

**NOTE:** The following equations are idealized. Back pressure at port 2 is excluded from these equations.

**NOTE:** Back pressure at port 2 adds to the effective setting at a rate of 1 plus the pilot ratio times the back pressure. Example: Using a 3:1 counterbalance valve with 200 psi of back pressure, the setting increase would be 800 psi.

Where:

L = Load-Induced Pressure

P = Pilot Pressure Required to Open Valve

P<sub>R</sub> = Pilot Ratio (e.g. 3:1 = 3)

S = Setting of Valve

C<sub>R</sub> = Cylinder Area Ratio =  $\left( \frac{\text{Bore Dia}^2}{\text{Bore Dia}^2 - \text{Rod Dia}^2} \right)$

1) Counterbalance valve on the blind end of the cylinder with a load retracting the cylinder rod.

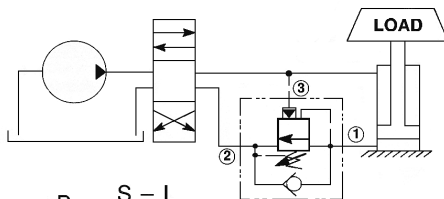

$$P = \frac{S - L}{P_R + \frac{1}{C_R}}$$

2) Counterbalance valve on the rod end of the cylinder with a load extending the cylinder rod.

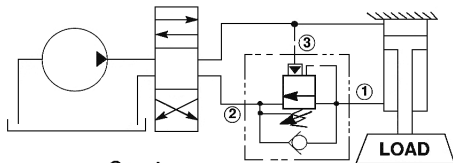

$$P = \frac{S - L}{P_R + C_R}$$

3) Counterbalance valve on a motor or an equal area actuator with an overrunning load.

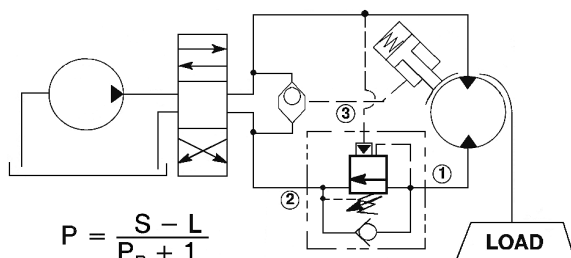

$$P = \frac{S - L}{P_R + 1}$$

- In general, lower pilot ratios provide better motion control and stability, especially on springy systems with high inertial loads.
- On motors, generally high pilot ratios will provide adequate dynamic control. However, spring-applied brakes should always be used to lock loads in a static position due to motor leakage.
- High pilot ratios improve hydraulic system efficiency (reduce heat generation), but at the cost of stability and smooth motion control.
- Counterbalance valves should not normally be used in closed-loop hydrostatic systems as they may cause overheating.
- Counterbalance valves are not low-pressure devices. Energy cannot be saved by using larger valves. System pressures should generally exceed 750 psi (50 bar).
- It is preferable that the valve be mounted close to the actuator providing maximum protection in the event of a hydraulic line failure. This can be achieved by incorporating them directly into the actuator, or Sun offers a range of gasket-mounted bodies that bolt directly onto the mounting face of a cylinder or motor.
- The setting of a counterbalance valve should be equal to at least 1.3 times the load pressure (1.5 times setting with valve set less than 2000 psi (140 bar)).
- **Remember**, with Sun counterbalance valves, turning the adjust screw clockwise (facing the valve) **lowers** the pressure setting, while counterclockwise movement **increases** the setting. (Think of the adjust screw as a manual override.)
- Slightly undersize rather than oversize a counterbalance valve; its purpose is to **create pressure drop**.
- Always use the lowest pilot ratio possible to maximize system/machine stability. The lower the pilot ratio, the better the control.
- The use of the 10:1 pilot ratio should be limited to motor circuits or circuits where the need is for the equivalent of a 10:1 pilot-operated check.
- Counterbalance valves will reseal at 85% of the cracking pressure.
- Counterbalance valves are tested for a maximum of 5 drops per minute at the **reseal** pressure. With the counterbalance valve set at 1.3 times the maximum load pressure, it should never see a maximum pressure greater than 77% of its setting (1/1.3), and therefore can be considered a zero-leak device.

## Counterbalance Application Notes (continued)

- Back pressure directly opposes the pilot pressure, and adds to the setting of the valve at 1+ pilot ratio times the back pressure for non-vented valves. (For a 3:1 ratio valve, back pressure raises the set point by 4 times the back pressure.)
- Although a counterbalance valve has a relief function, it should not be considered as a “good” relief valve. (As a pure relief valve, stability, noise, and, in high cyclic applications, durability can become issues.)
- System stability can almost always be improved by adding an accumulator in the pilot line (by keeping the pilot pressure steadier).
- System stability can always be improved by adding a meter-out restrictive flow control between the cylinder or motor port and the counterbalance valve (by reducing the metering required of the counterbalance valve).
- Vented counterbalance valves have high-gain relief characteristics similar to direct-acting sequence valves (i.e. small changes in pilot pressure result in large flow changes), as compared to non-vented valves. Using a vented counterbalance valve can result in lowering a machine’s stability. Variable back pressure from other system components, such as a proportional valve, should take care of this issue. This back pressure is the reason for using the vented version in the first place!

**Counterbalance valves should be pressure set prior to installation into a system for more than just safety reasons. They are very difficult to accurately set once installed on a machine. On rare occasions, it may be necessary to adjust the valve after installation. Following is a suggested setting method that can be used in an emergency. Keep in mind it is strongly recommended that counterbalance cartridges always be factory set by Sun.**

### Emergency setting of counterbalance cartridges when installed in a system by visually observing maximum load pressure via the system gauge.

1. Observe all safety requirements regarding the operation of the machine and associated device.
2. Ensure that you are in control of the hydraulic support for the equipment and that no unanticipated **hazardous** machine movements can occur.
3. Make note of any “pinch points” and make sure any machine movement that occurs during the adjustment phase will not cause injury. Note, especially, the location of the counterbalance valve adjustment as it relates to this movement.
4. To increase the setting, the rotation adjustment is **counterclockwise**, and setting will not be exact due to circuit interactions and the manner in which the valve is adjusted.

5. If there is no hydraulic system pressure gauge, install one so system pressure can be observed and noted.
6. Start with the counterbalance valve at the standard factory setting. This information is shown on the “Sun Counterbalance Valve Pressure Setting vs. Turns” table on page 9, as well as individual cartridge product pages shown on the Sun web site.
7. If your valve has a “C” or “J” range (2000-5000 psi / 140-350 bar) or a “G” range (2000-6000 psi / 140-350 bar), increase the setting one full turn (counterclockwise) before proceeding.
8. Set up the machine with the **maximum** load on the actuator that is being supported by the counterbalance valve. (If the actuator causes angular motion, make sure the actuator is in the maximum load position.) Slightly and slowly (with minimum flow) raise the load.
9. Observe the gauge and record the maximum pressure generated when raising the load.
10. Using the “Sun Counterbalance Valve Pressure Setting vs. Turns” table on page 9, verify the amount of pressure per turn corresponding to your model valve. Multiply the observed load pressure by 1.3 and readjust the counterbalance valve to the calculated pressure by either increasing (turning counterclockwise) or decreasing (turning clockwise) to vary the setting. *Note:* You will **not** be able to observe the final setting of the valve on the gauge, as this setting will be **higher** than the highest load-induced pressure.)

### An example of this setting procedure:

Counterbalance Valve: CBCA-LHN

Setting range: 1000-4000 psi / 70-280 bar

Factory Setting: 3000 psi / 207 bar (unless stamped otherwise)

1. Maximum gauge (load) pressure observed when slowly raising (moving) the load at maximum load point = 2600 psi (179 bar)
2. Multiplying load pressure by 1.3 (1.3 x 2600) = 3380 psi (233 bar). This is the recommended counterbalance valve setting for this application.
3. From the table on page 9, CBCA-LHN has an adjustment rate of 1275 psi (89 bar) per turn. Subtract the factory setting from the gauge reading and divide the total by the adjustment rate of the table.

$$\frac{3380 - 3000}{1275} = + 0.3 \text{ turns (counterclockwise)}$$

For reference, if the maximum load pressure happens to be lower than the factory setting, the calculation will yield a negative number of turns (clockwise). Also, if you have a valve with a range noted in number 7 above and have readjusted the valve, the pressure for one turn noted in the table on page 8 must be added to the factory setting. For example: the revised setting for a CBCG-LJN would be 3000 psi (210 bar) + 1760 psi (120 bar) or 4760 psi (330 bar).

4. Adjust the counterbalance valve as calculated above by loosening the lock nut and turning the adjust screw (approximately 1/3 turn or 2 wrench flats) counterclockwise on the adjust screw in the above example.
5. Retighten the locknut to the specified torque, being careful not to turn the adjust screw.

## SUN'S COUNTERBALANCE CARTRIDGE VALVES

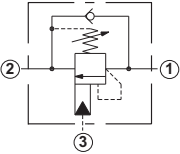
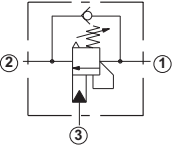
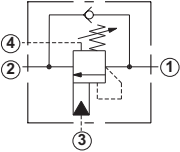
Type	Gain Characteristics in Flow	Series 1	Series 2	Series 3	Series 4	Pilot Ratio	Maximum Setting psi (bar)	Back Pressure Multiplier	
<b>Three-Port, Non-Vented</b>  		<b>5 gpm (20 L/min.)</b>	<b>8 gpm (30 L/min.)</b>	<b>15 gpm (60 L/min.)</b>	<b>20 gpm (80 L/min.)</b>				
	Restrictive	CBBY <sub>1</sub>				2:1	4000 (280)	4	
	Restrictive	CBBA <sub>2</sub>	CBDA <sub>2</sub>	CBFA <sub>2</sub>	CBHA <sub>2</sub>	3:1	4000 (280)	4	
	Restrictive	CBBG <sub>2</sub>	CBDG <sub>2</sub>	CBFG <sub>2</sub>	CBHG <sub>2</sub>	4.5:1	5000 (350)	5.5	
			<b>10 gpm (40 L/min.)</b>	<b>20 gpm (80 L/min.)</b>	<b>40 gpm (160 L/min.)</b>				
	Semi-restrictive	CBBB <sub>2</sub>	CBDB <sub>2</sub>	CBFB <sub>2</sub>		1.5:1	4000 (280)	2.5	
	Semi-restrictive	CBBL <sub>2</sub> *	CBDL <sub>2</sub>	CBFL <sub>2</sub>		2.3:1	5000 (350)	3.3	
	Semi-restrictive	CBBC <sub>2</sub>	CBDC <sub>2</sub>	CBFC <sub>2</sub>		3:1	4000 (280)	4	
	Semi-restrictive	CBBD <sub>2</sub> *	CBDD <sub>2</sub>	CBFD <sub>2</sub>		4.5:1	5000 (350)	5.5	
			<b>15 gpm (60 L/min.)</b>	<b>30 gpm (120 L/min.)</b>	<b>60 gpm (240 L/min.)</b>	<b>120 gpm (480 L/min.)</b>			
	Standard	CBCB <sub>2</sub>	CBEB <sub>2</sub>	CBGB <sub>2</sub>	CBIB <sub>2</sub>	1.5:1	4000 (280)	2.5	
	Standard	CBCY <sub>1</sub>	CBEY <sub>1</sub>	CBGY <sub>2</sub>	CBYI <sub>2</sub>	2:1	4000 (280)	4	
	Standard	CBCL <sub>2</sub>	CBEL <sub>2</sub>	CBGL <sub>2</sub>	CBIL <sub>2</sub>	2.3:1	5000 (350)	3.3	
	Standard	CBCA <sub>3</sub> *	CBEA <sub>3</sub>	CBGA <sub>2</sub>	CBIA <sub>2</sub>	3:1	4000 (280)	4	
	Standard	CBCG <sub>3</sub> *	CBEG <sub>3</sub>	CBGG <sub>2</sub>	CBIG <sub>2</sub>	4.5:1	5000 (350)	5.5	
	Standard	CBCH <sub>3</sub>	CBEH <sub>3</sub>	CBGH <sub>2</sub>	CBIH <sub>2</sub>	10:1	5000 (350)	11	
	<b>Three-Port, Atmospherically Referenced</b>  	Standard	CACK <sub>2</sub>	CAEK <sub>2</sub>	CAGK <sub>2</sub>	CAIK <sub>2</sub>	1:1	4000 (280)	0
		Standard	CACL <sub>2</sub>	CAEL <sub>2</sub>	CAGL <sub>2</sub>	CAIL <sub>2</sub>	2:1	6000 (420)	0
Standard		CACA <sub>2</sub>	CAEA <sub>2</sub>	CAGA <sub>2</sub>	CAIA <sub>2</sub>	3:1	4000 (280)	0	
Standard		CACG <sub>2</sub>	CAEG <sub>2</sub>	CAGG <sub>2</sub>	CAIG <sub>2</sub>	5:1	6000 (420)	0	
			<b>7.5 gpm (30 L/min.)</b>	<b>30 gpm (120 L/min.)</b>	<b>60 gpm (240 L/min.)</b>	<b>120 gpm (480 L/min.)</b>			
		CABG				4.5:1	4000 (280)	0	
		CABK	CAEK	CAGK	CAIK	1:1	4000 (280)	0	
		CABN				7:1	4000 (280)	0	
<b>Four-Port, Vented</b>  			<b>T-21A</b>	<b>T-22A</b>	<b>T-23A</b>	<b>T-24A</b>			
		Standard	CWCK <sub>2</sub>	CWEK <sub>2</sub>	CWVK <sub>2</sub>	CWIK <sub>2</sub>	1:1	4000 (280)	0
	Standard	CWCL <sub>2</sub>	CWEL <sub>2</sub>	CWVL <sub>2</sub>	CWIL <sub>2</sub>	2:1	6000 (420)	0	
	Standard	CWCA <sub>2</sub>	CWEA <sub>2</sub>	CWVA <sub>2</sub>	CWIA <sub>2</sub>	3:1	4000 (280)	0	
	Standard	CWCG <sub>2</sub>	CWEG <sub>2</sub>	CWVG <sub>2</sub>	CWIG <sub>2</sub>	5:1	6000 (420)	0	
		CWBG				4.5:1	4000 (280)	0	
		CWBK	CWEK	CWVK	CWIK	1:1	4000 (280)	0	

- 1 Bleed-through pilots
- 2 Sealed pilots
- 3 Limited leakage – non-sealed pilot

\* Certain models are available with fixed setting: e.g. CBBL-X\*\*

**Pilot Gain Characteristic:** A descriptive term regarding the oil metering “flow gain” of the valve. Restrictive (lowest gain, and most stable indicates a small change in flow for a large change in pilot pressure), Semi-restrictive, to Standard (highest gain).

**Flow Gain Remarks:** Use a valve within the appropriate flow range for the application. Choosing a valve with too large a capacity will compromise gain and stability. Nominal flow ratings are indicated in bold (Example: 5 gpm (20 L/min.)) above each series size category.

**Machine Stability:** A low-frequency oscillation caused by the interaction of the complex mass/spring relationships of a typical machine.

If machine stability problems exist, change to a valve with a lower pilot ratio or lower gain rating or combination of both.

**Back-Pressure Multiplier:** The indicated value is the multiplier effect back pressure has on the relief setting of the valve. A small number is better.

*This selection chart is simply a guide and is not intended to be used in place of thorough system testing.*



**SUN COUNTERBALANCE VALVE PRESSURE SETTING VS. TURNS**

The pressure ranges shown in the table below are the **Preferred Load Holding Adjustment Ranges**. However, all of the cartridges listed below can be adjusted down to 200 psi (14 bar) or less, and the “Approximate psi (bar) vs. Turn” column covers pressures starting at the **preferred minimum** pressure setting and are effective up to a maximum pressure which, in most cases, will be above the listed **preferred maximum** value shown for an individual cartridge. “**Approximate psi (bar) vs. Turn Values**” should be considered “nominal” and can vary somewhat from valve to valve.

Cartridge Model	Series	Total Number of Turns	Pressure - psi (bar) (Adjustment Range)	Approximate psi (bar) vs. Turn	Standard Setting psi (bar)
CBB*-*A* / CBB*-*H* / CBC*-*A* / CBC*-*H*	1	3.75 - 4.0	1000-4000 (70-280)	1275 (89)	3000 (210)
CBB*-*B* / CBB*-*I* / CBC*-*B* / CBC*-*I*	1	3.75 - 4.0	400-1500 (25-105)	880 (62)	1000 (70)
CBB*-*C* / CBB*-*J* / CBC*-*C* / CBC*-*J*	1	3.75 - 4.0	2000-5000 (140-350)	1760 (123)	3000 (210)
CBB*-*D* / CBB*-*K* / CBC*-*D* / CBC*-*K*	1	3.75 - 4.0	1000-2500 (70-175)	1250 (87)	2000 (140)
CBD*-*A* / CBD*-*H* / CBE*-*A* / CBE*-*H*	2	3.75 - 4.0	1000-4000 (70-280)	1300 (91)	3000 (210)
CBD*-*B* / CBD*-*I* / CBE*-*B* / CBE*-*I*	2	3.75 - 4.0	400-1500 (25-105)	580 (41)	1000 (70)
CBD*-*C* / CBD*-*J* / CBE*-*C* / CBE*-*J*	2	3.75 - 4.0	2000-5000 (140-350)	1880 (132)	3000 (210)
CBD*-*D* / CBD*-*K* / CBE*-*D* / CBE*-*K*	2	3.75 - 4.0	1000-2500 (70-175)	1000 (70)	2000 (140)
CBF*-*A* / CBF*-*H* / CBG*-*A* / CBG*-*H*	3	3.75 - 4.0	1000-4000 (70-280)	1400 (98)	3000 (210)
CBF*-*B* / CBF*-*I* / CBG*-*B* / CBG*-*I*	3	3.75 - 4.0	400-1500 (25-105)	660 (46)	1000 (70)
CBF*-*C* / CBF*-*J* / CBG*-*C* / CBG*-*J*	3	3.75 - 4.0	2000-5000 (140-350)	2100 (147)	3000 (210)
CBF*-*D* / CBF*-*K* / CBG*-*D* / CBG*-*K*	3	3.75 - 4.0	1000-2500 (70-175)	900 (63)	2000 (140)
CBH*-*A* / CBH*-*H* / CBI*-*A* / CBI*-*H*	4	3.75 - 4.0	1000-4000 (70-280)	1600 (112)	3000 (210)
CBH*-*B* / CBH*-*I* / CBI*-*B* / CBI*-*I*	4	3.75 - 4.0	400-1500 (25-105)	770 (54)	1000 (70)
CBH*-*C* / CBH*-*J* / CBI*-*C* / CBI*-*J*	4	3.75 - 4.0	2000-5000 (140-350)	2340 (164)	3000 (210)
CBH*-*D* / CBH*-*K* / CBI*-*D* / CBI*-*K*	4	3.75 - 4.0	1000-2500 (70-175)	1280 (90)	2000 (140)
CAC*-*H* / CWC*-*H*	1	5.0 - 5.5	1000-4000 (70-280)	750 (53)	3000 (210)
CAC*-*I* / CWC*-*I*	1	5.0 - 5.5	400-1500 (25-105)	330 (23)	1000 (70)
CAC*-*F* / CWC*-*F*	1	5.0 - 5.5	1000-2500 (70-175)	490 (34)	2000 (140)
CAC*-*G* / CWC*-*G*	1	5.0 - 5.5	2000-6000 (140-420)	1050 (76)	4000 (280)
CAE*-*H* / CWE*-*H*	2	5.0 - 5.5	1000-4000 (70-280)	860 (60)	3000 (210)
CAE*-*I* / CWE*-*I*	2	5.0 - 5.5	400-1500 (25-105)	280 (20)	1000 (70)
CAE*-*F* / CWE*-*F*	2	5.0 - 5.5	1000-2500 (70-175)	420 (29)	2000 (140)
CAE*-*G* / CWE*-*G*	2	5.0 - 5.5	2000-6000 (140-420)	1220 (85)	4000 (280)
CAG*-*H* / CWG*-*H*	3	5.0 - 5.5	1000-4000 (70-280)	800 (56)	3000 (210)
CAG*-*I* / CWG*-*I*	3	5.0 - 5.5	400-1500 (25-105)	310 (22)	1000 (70)
CAG*-*F* / CWG*-*F*	3	5.0 - 5.5	1000-2500 (70-175)	390 (27)	2000 (140)
CAG*-*G* / CWG*-*G*	3	5.0 - 5.5	2000-6000 (140-420)	1275 (89)	4000 (280)
CAI*-*H* / CWI*-*H*	4	5.0 - 5.5	1000-4000 (70-280)	760 (53)	3000 (210)
CAI*-*I* / CWI*-*I*	4	5.0 - 5.5	400-1500 (25-105)	280 (20)	1000 (70)
CAI*-*F* / CWI*-*F*	4	5.0 - 5.5	1000-2500 (70-175)	440 (31)	2000 (140)
CAI*-*G* / CWI*-*G*	4	5.0 - 5.5	2000-6000 (140-420)	1240 (87)	4000 (280)
CAB*-*H* / CWB*-*H*	1	3.75 - 4.0	1000-4000 (70-280)	1275 (89)	3000 (210)



Sun Hydraulics Headquarters  
Sarasota, Florida USA  
+1 941 362 1200

Sun Hydraulics Limited  
Coventry, England  
+44 2476 217 400  
[sales@sunuk.com](mailto:sales@sunuk.com)

Sun Hydraulik GmbH  
Erkelenz, Germany  
+49 2431 80910  
[sales@sunhydraulik.de](mailto:sales@sunhydraulik.de)

Sun Hydraulics Corp. (India)  
Bangalore, India  
+91 8028 456325  
[sunindiainfo@sunhydraulics.com](mailto:sunindiainfo@sunhydraulics.com)

Custom Fluidpower Pty Ltd  
(A Sun Hydraulics Company)  
Newcastle, Australia  
+61 2 4953 5777  
[sales@custom.com.au](mailto:sales@custom.com.au)

Sun Hydraulics Korea Corp.  
Incheon, Korea  
+82 3281 31350  
[sales@sunhydraulics.co.kr](mailto:sales@sunhydraulics.co.kr)

Sun Hydraulics China Co. Ltd.  
Shanghai, P.R. China  
+86 2162 375885  
[sunchinainfo@sunhydraulics.com](mailto:sunchinainfo@sunhydraulics.com)

Sun Hydraulics Corp. (S.America)  
Rosario, Argentina  
+54 9 341 584 3075  
[ventas@sunhydraulics.com](mailto:ventas@sunhydraulics.com)