

Sun FLeX Series Solenoid Valves

HIGH RELIABILITY

10 million on-off operational cycles

LOW INTERNAL LEAKAGE

Less than one drop per minute

USES FLeX SERIES DC COILS

High-power (5000 psi)
& hazardous location coils

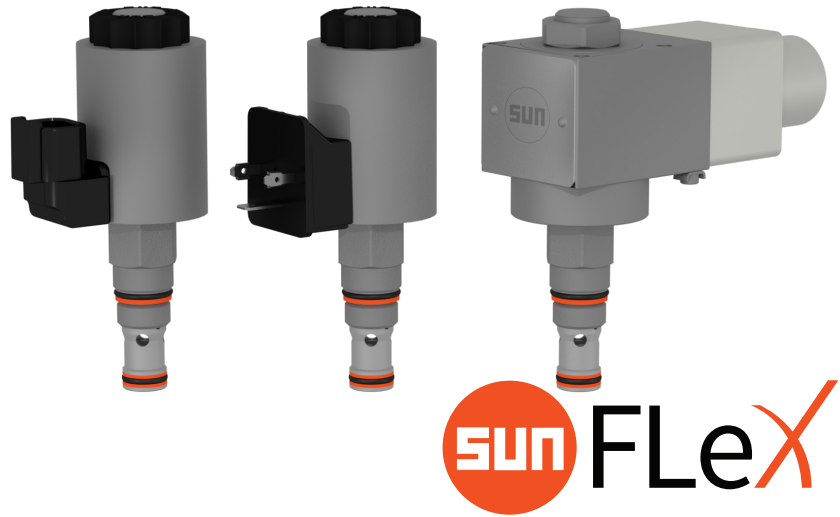

FPB*

5000 psi (350 bar)

PILOT-OPERATED ELECTRO-PROPORTIONAL THROTTLE VALVES

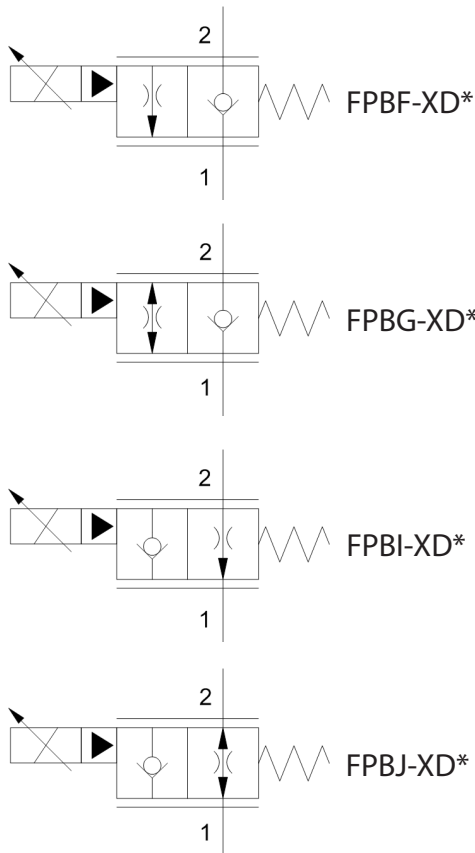

TABLE OF CONTENTS

Valve Functionality	2
Technical Features	2
Model Configurations & Options	3
Technical Specifications	4
Performance Curves	5
Dimensional Drawings	6
Cavity Drawings/Tooling	7
Additional Information	8

sunhydraulics.com/model/FPB*

FPB*

PILOT-OPERATED ELECTRO-PROPORTIONAL THROTTLE VALVE

The 2/2 proportional poppet valves are pilot operated. They comprise a hex body (3), solenoid with coil (2), poppet (5), dart (4), coil nut (1), ball (6), pin (7), and two springs (8 & 9) for the FPBG and FPBF, and one spring (8) for the FPBJ and FPBI.

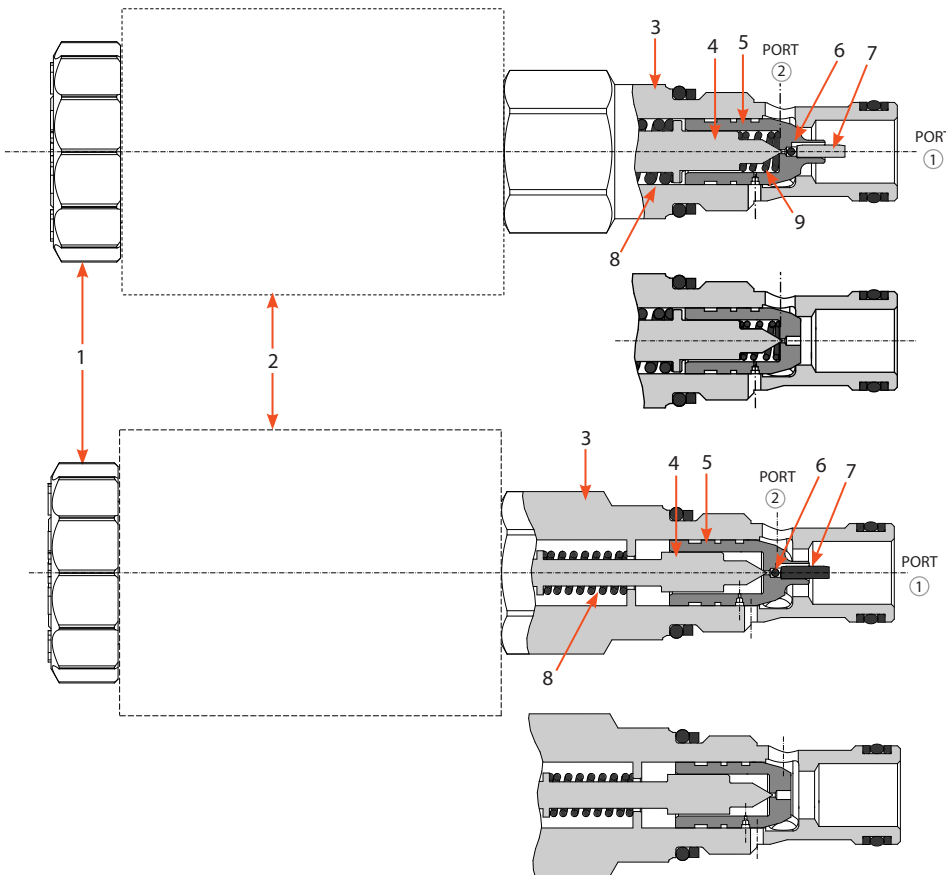

FPBG & FPBF (normally closed)

Function: When de-energized, the dart (4) rests on the poppet (5) which in turn rests on the sleeve seat (3). In this condition, flow is blocked from 2 to 1 but will free flow from 1 to 2. When energized, the dart lifts from the poppet proportional to the coil current. The poppet then follows the dart and lifts from the seat, opening flow from 2 to 1.

If the FPBF is open and flow is routed 1 to 2, the valve will auto close and only pilot flow will pass from 1 to 2. For the FPBG, the check valve (6 & 7) at the nose of the poppet will allow free flow 1 to 2 whether the valve is open or closed.

FPBJ & FPBI (normally open)

Function: When de-energized, the dart (4) and poppet (5) are held away from the sleeve seat by the spring (8), opening flow from 2 to 1. When energized, the dart pushes into the poppet seat proportional to the coil current. As the dart pushes against the spring, the poppet pushes into the sleeve seat, closing the valve. Flow is then blocked from 2 to 1 but can free flow from 1 to 2.

If the FPBI is open and flow is routed from 1 to 2, the valve will auto close and only pilot flow will pass from 1 to 2. For the FPBJ, the check valve (6 & 7) at the nose of the poppet will allow free flow 1 to 2 whether the valve is open or closed.

TECHNICAL FEATURES

- All FLeX Series valves incorporate the Sun floating-style construction to minimize the possibility of internal parts binding due to excessive installation torque and/or cavity/cartridge machining variations.
- FLeX Series proportional valves are fully compatible with the XMD Expandable Mobile Drivers from Sun.
- Designed and tested to exceed 10 million on-off operational cycles.
- Meets new NFPA test standard T2.6.1 R2014 for fatigue and burst pressure ratings.
- Improved linearity and resolution over similar competing valves.
- Designed using CFD fluid simulation for optimized geometries.
- For optimum performance, an amplifier with current feedback and adjustable dither (100 - 250 Hz) should be used.
- Capacities rated at 200-psi (14-bar) differential and maximum rated coil current.
- Depending on circuit requirements, a reverse free flow check bypassing the compensator may be needed when using an FPB* with an external compensator.
- Zinc-nickel plating standard for 1000-hour salt fog protection.
- The 5000-psi (350-bar) FPB* valves can be used with the high-power and hazardous location FLeX coils.
- A wide variety of coil termination and voltage options are available, with and without surge protection. See the CONFIGURATION section.
- Coil connector options offer ratings up to IP69K. See individual coil product pages for details.

MODEL CODE EXPLANATION

Sun cartridges have a base seven-digit part number. Each of the digits in the sequence has significance as shown in the model code explanation below. Available options and

modifiers for specific cartridges, manifolds, and valve packages are shown on the individual product pages and data sheets. All modifiers are not applicable for every model.

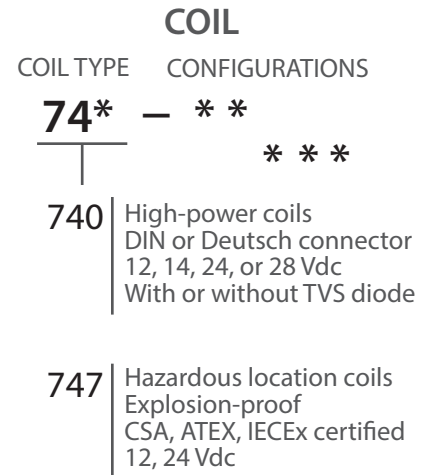
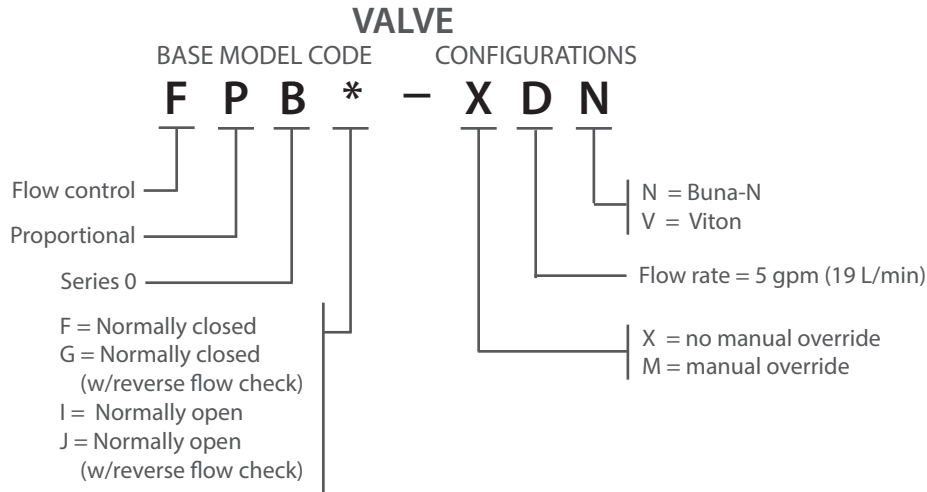

Important Note:

When performing model code searches on www.sunhydraulics.com, do not include setting(s). When ordering, no spaces or dashes are used.

See individual coil data sheets for full coil configuration.

COMPATIBLE FLeX SERIES COILS

High-Power (25-W) Coils

Voltage	DIN 43650 Form A (IP65/IP67)	Deutsch DT04-2P (IP69K)	Resistance @20°C (ohms) ±10% (with diode*)	TVS Diode (Nominal) Breakdown Voltage (with diode*)
12 Vdc	740-212	740-912	5.8 ohms	68 Vdc
14 Vdc	740-214	740-914	7.8 ohms	68 Vdc
24 Vdc	740-224	740-924	23.0 ohms	68 Vdc
28 Vdc	740-228	740-928	31.4 ohms	68 Vdc

* Above model codes are shown without transient voltage suppression (TVS) diodes. To order FLeX coils with a TVS diode, append model code with "D" (Example: 740-212LD).

Hazardous Location, Explosion-Proof (30-W) Coils

Voltage	M20 x 1.5 180°	M20 x 1.5 90°	1/2" NPT 180°	1/2" NPT 90°	Resistance 20° C (ohms)	TVS Diode (Nominal) Breakdown Voltage
12 Vdc	747-JM12BD	747-JM12CD	747-JN12BD	747-JN12CD	4.9 ohms	48 Vdc
24 Vdc	747-JM24BD	747-JM24CD	747-JN24BD	747-JN24CD	19.3 ohms	48 Vdc



PILOT-OPERATED ELECTRO-PROPORTIONAL
THROTTLE VALVE

SERIES 0
CAVITY: T-162A

TECHNICAL SPECIFICATIONS

Sun Cavity	T-162A
Sun Cartridge Series	Series 0
Nominal Flow / Capacity	5 gpm (18.9 L/min)*
Maximum Operating Pressure	5000 psi (350 bar)
Check Cracking Pressure - Typical	100 psi (6.9 bar)
Response Time - Typical	50 ms (open & close)
Maximum Internal Leakage at 110 SUS (24 cSt) at 5000 psi (350 bar)	0.004 in ³ (0.07 cc ³)/min (1 drop/min)
Switching Frequency (Maximum)	15,000 cycles/hour
Recommended Dither Frequency	140 Hz
Hysteresis (at Recommended Dither)	15%
Linearity (at Recommended Dither)	3%
Repeatability (at Recommended Dither)	3%
Deadband, Nominal (as Percent of Coil Current)	48%
Manual Override Option	No
Viscosity Range	2,8 to 380 cSt or 35 to 2000 SUS
Filtration	Minimum cleanliness (ISO 4406 1999, 4/6/14 µm) 18/16/13
Valve Hex Size	0.75 in (19,1 mm)
Valve Installation Torque	20–25 lbf ft (27–34 N-m)
Mounting Position	No restrictions
Valve Weight (excluding coil)	5.6 oz (159 g)
Seal Kit - Viton	990-608-006
Seal Kit - Buna	990-608-007

* See performance curves on P 5 for more details.

TYPICAL FLOW VS. COMMAND

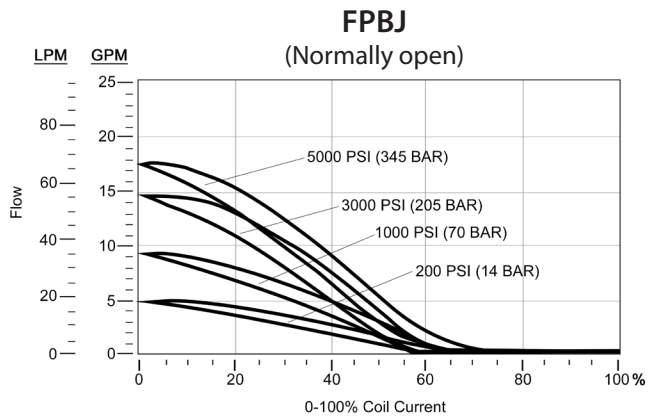
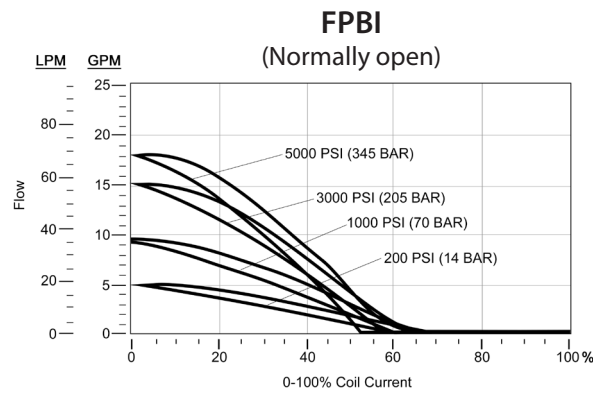
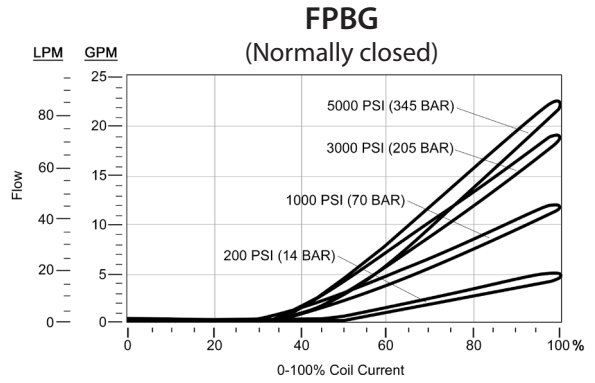
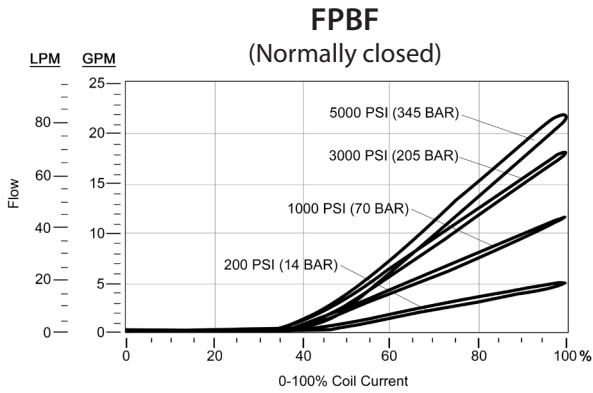

TYPICAL PRESSURE DIFFERENTIAL VS. FLOW

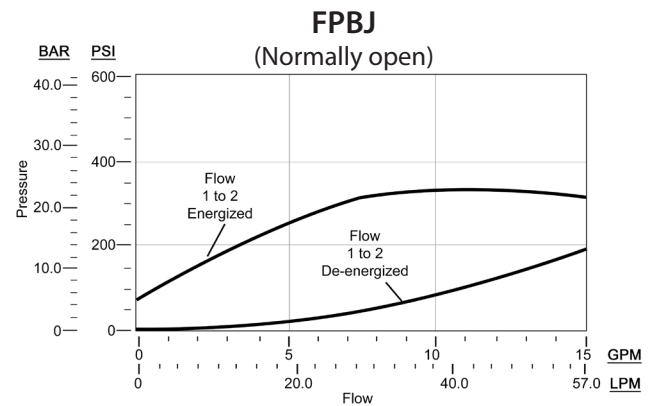
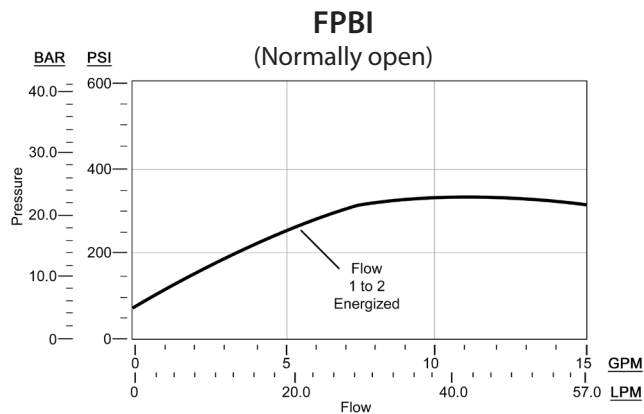
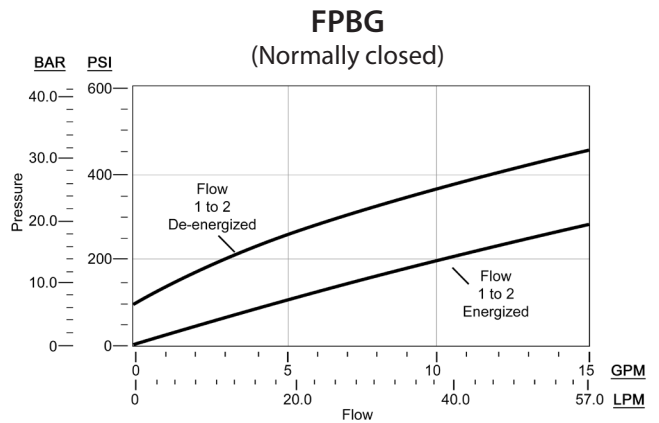
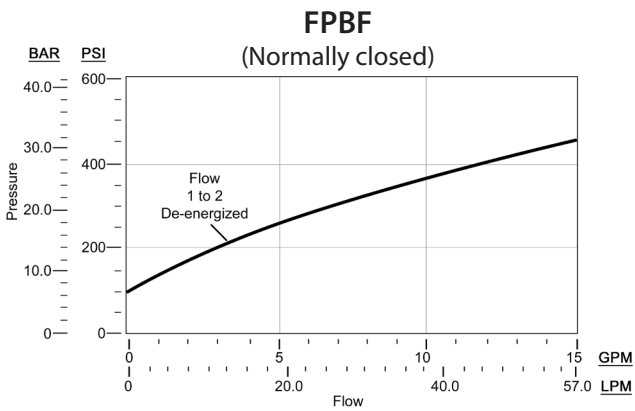

FPB* FAMILY WITH 740 SERIES HIGH-POWER COILS

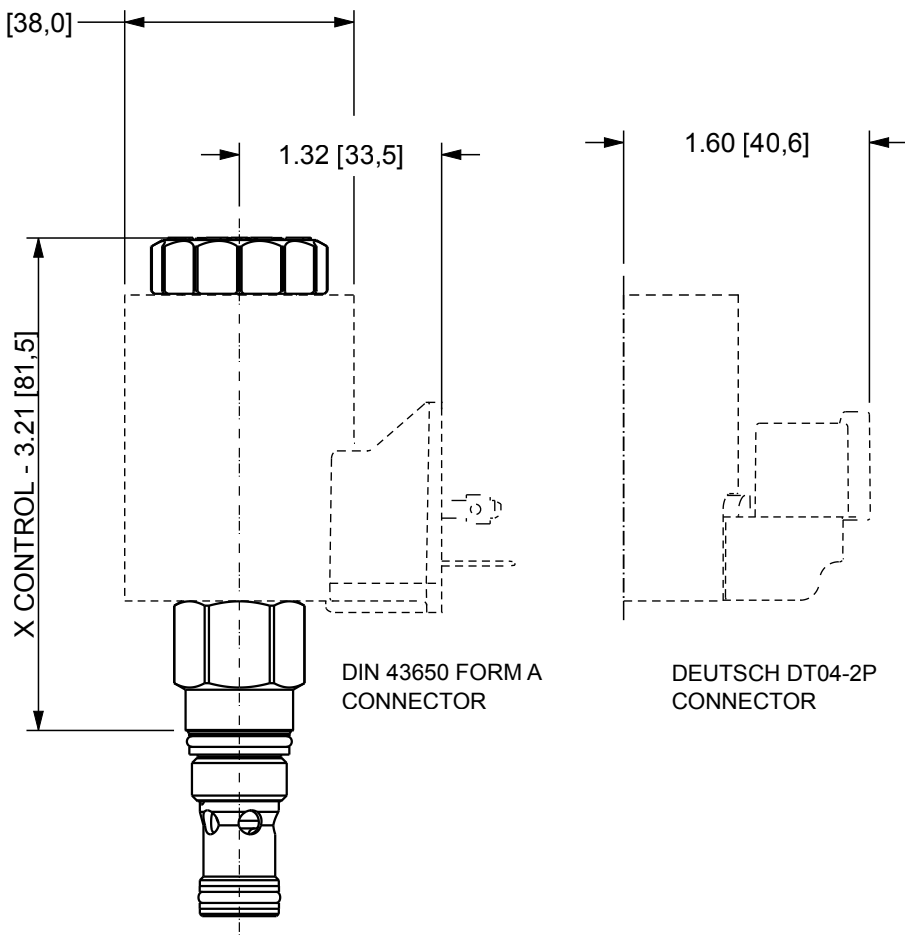

747 SERIES HAZARDOUS LOCATION COILS

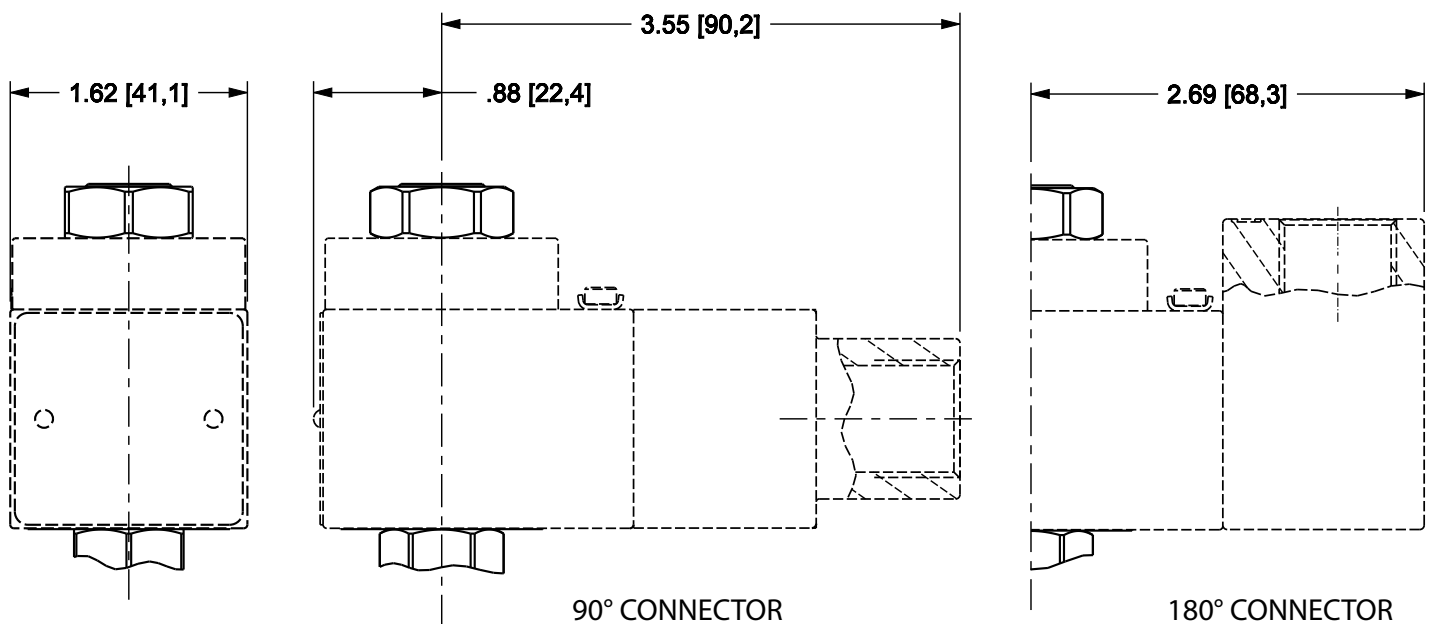

NOTE: Please verify cartridge clearance requirements when choosing a Sun manifold. Different valve controls and coils require different clearances. An additional minimum 2.0 in. (50,8 mm) beyond the valve extension is needed for coil installation and removal.

T-162A CAVITY DIMENSIONAL DRAWING

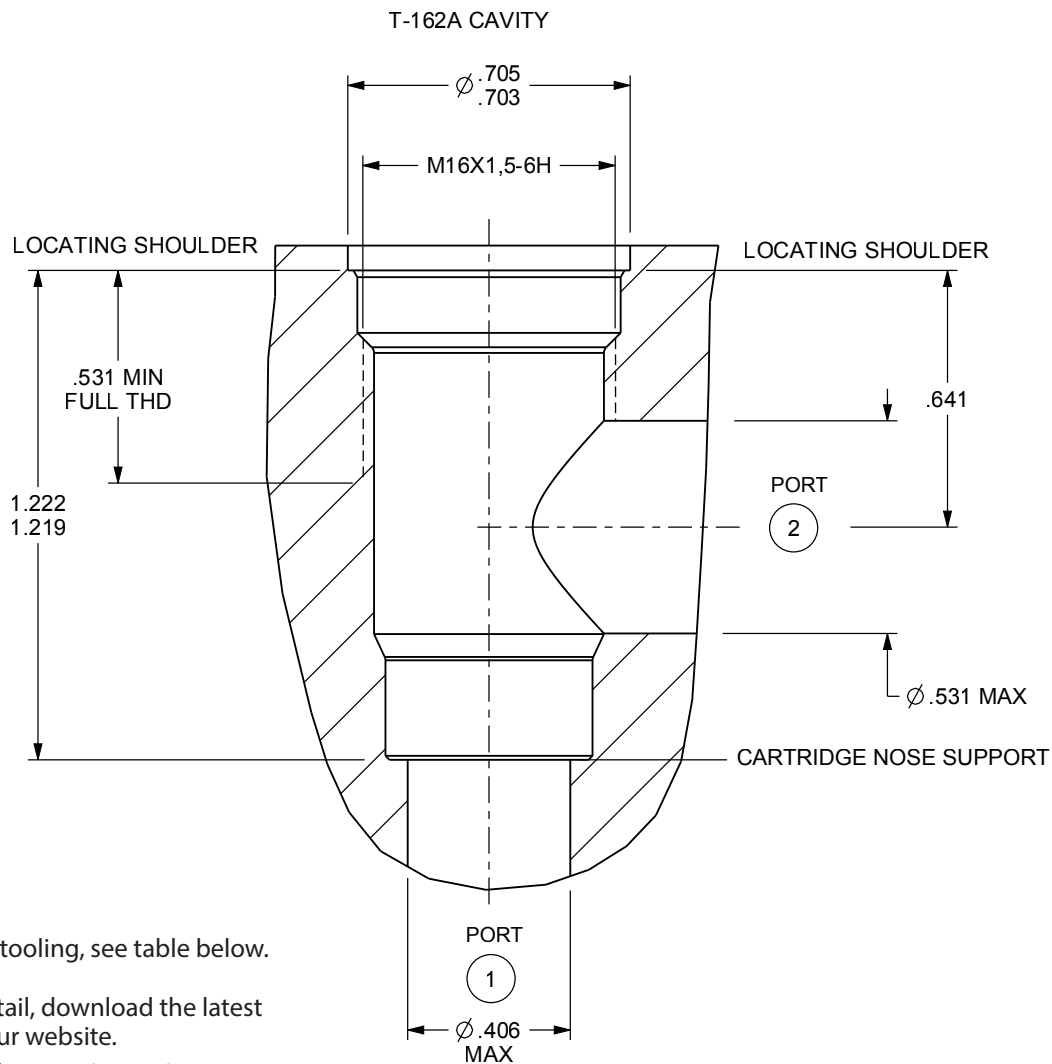

T-162A CAVITY TOOLING

DESCRIPTION	HIGH-SPEED STEEL	TITANIUM COATED
M16 X 1.5-6H tap, straight shank	998991	998991101
Series 0 deep hex socket	998100005	
T-162A cavity form drill, morse taper	994162001	994162101
T-162A cavity form drill, straight shank		994162102
T-162A cavity form reamer, morse taper	995162001	995162101
T-162A cavity form reamer, straight shank		995162102

ADDITIONAL INFORMATION

ACCESSORIES

XMD Single- and Dual-Output Drivers

The XMD is a single- or dual-output driver used with solenoid-operated electro-proportional valves for the mobile and industrial hydraulic industries. The driver can be mounted on a manifold using the standard mount clip or directly to the FLeX Series low- and high-power coils using an optional coil-mount clip.

DESCRIPTION	PART NUMBER
Single-output PWM driver w/ standard mounting bracket	XMD-01
Dual-output PWM driver w/ standard mounting bracket	XMD-02
FLeX high-power coil clip assembly	990-740-001
FLeX low-power coil clip assembly	990-740-002



Wire Harnesses

DESCRIPTION	PART NUMBER
Wire harness, 2-pin Deutsch-to-Metri-Pack Conversion	991-717
Wire harness, 2-pin Deutsch-to-Amp Jr Timer Conversion	991-718
Wire harness, 2-pin Deutsch-to-Twin-Lead Conversion	991-719

STANDARD LINE-MOUNT & SANDWICH MANIFOLDS

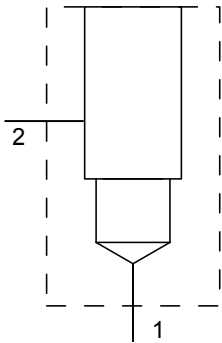

Compatible with the FPB* family of FLeX valves, Sun Hydraulics offers 31 standard line-mount manifolds in 90°, in-line, through port 1 with gauge port, cross port and direct mount (banjo bolt) versions for the T-162A cavity. Standard products include one- and two-cavity versions in a wide range of port sizes. The popular AAJ model line-mount 90° manifold (shown at left) has a single cavity and SAE 8 ports.

In sandwich manifolds, we offer 26 standard bodies based on the T-162A cavity that include a range of interfaces in one- or two-cavity versions.

To search our complete line of standard manifolds, go to www.SunHydraulics.com/models/manifolds.



Sun Hydraulics Headquarters
Sarasota, Florida USA
(1) 941 362 1200
suninfo@sunhydraulics.com

Sun Hydraulics Limited
Coventry England
+44 2476 217 400
sales@sunuk.com

Sun Hydraulik GmbH
Erkelenz Germany
+49 2431 80910
sales@sunhydraulik.de

Sun Hydraulics Corp. (India)
Bangalore India
+91 8028 456325
sunindiainfo@sunhydraulics.com

Sun Hydraulics Korea Corp.
Incheon Korea
+82 3281 31350
sales@sunhydraulics.co.kr

Sun Hydraulics China Co. Ltd.
Shanghai P.R. China
+86 2151 162862
sunchinainfo@sunhydraulics.com

Sun Hydraulics Corp. (S.America)
Rosario, Argentina
+54 9 341 584 3075
ventas@sunhydraulics.com

October 2017